

KS12-200AH(12V200Ah/10HR)

VALVE REGULATED LEAD-ACID BATTERY

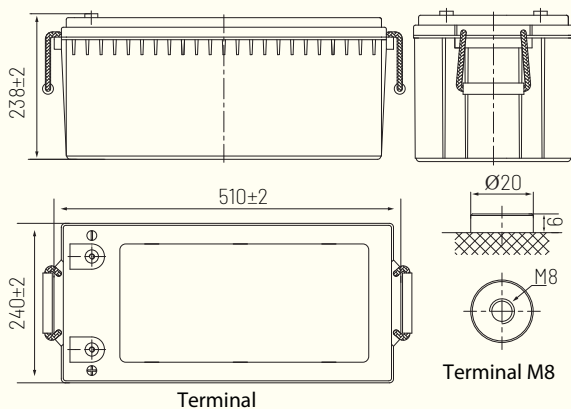

Dimensions



- ABS container;
- Absorbent glass mat technology (AGM).

Applications

- Uninterruptable Power Supply (UPS)
- Electric Power System (EPS)
- Emergency backup power supply
- Alarm and security system
- DC power supply
- Auto control system

General Features

- 10 years design life (25°C)
- Lead calcium alloy, sealed design, no watering required
- Puncture resistant micro-porous glass mat separators extend life
- Unique technology optimizes power capacity, cell consistency, and long-term reliability
- Designed for a wide range of applications

Standards

- Compliance with IEC 60896 standards EU Battery Directive
- Manufactured by ISO & CE certified Company

Specifications

Nominal Voltage		12V
Capacity (25°C)	10HR (10.80V)	200Ah
	5HR (10.50V)	175Ah
	1HR (9.60V)	124Ah
Dimension	Length	510±2mm
	Width	240±2mm
	Height	238±2mm
	Total Height	238±2mm
Approx. Weight		56.30kg±5%
Terminal type		M8
Internal resistance (Fully charged, 25°C)		Approx. 3.2 mΩ
Capacity affected by temperature (20HR)	40°C	102%
	25°C	100%
	0°C	85%
	-15°C	65%
Self-discharge (25°C)	3 month	Remaining Capacity: 91%
	6 month	Remaining Capacity: 82%
	12 month	Remaining Capacity: 65%
Nominal operating temperature		25°C±3°C (77°F±5°F)
Operating temperature range	Discharge	-15°C ~ 50°C (5°F ~ 122°F)
	Charge	-10°C ~ 50°C (14°F ~ 122°F)
	Storage	-20°C ~ 50°C (-4°F ~ 122°F)
Float charging voltage (25°C)		13.50 to 13.80V Temperature compensation: -18mV/°C
Cyclic charging voltage (25°C)		14.10 to 14.40V Temperature compensation: -30mV/°C
Standard / Maximum charging current		20A /60A
Terminal material		Copper
Maximum discharge current		1600A (5 sec.)
Designed floating life (25°C)		10 years

VALVE REGULATED LEAD-ACID BATTERY

Discharge Table

Constant Current Discharge (Amperes) at 25°C (77°F)																
F.V/Time	5min	10min	15min	20min	30min	45min	1h	1.5h	2h	3h	4h	5h	6h	8h	10h	20h
1.85V/cell	328.7	287.1	254.0	199.7	178.6	130.6	110.6	80.2	67.4	49.4	38.8	33.7	29.7	22.8	18.9	10.0
1.80V/cell	372.4	325.8	287.8	225.8	194.4	138.4	114.6	82.9	69.6	53.7	41.4	35.4	31.9	24.0	20.0	10.4
1.75V/cell	403.2	353.4	311.6	243.8	198.4	143.4	120.2	87.1	73.3	54.7	42.2	36.0	32.1	24.1	20.1	10.5
1.70V/cell	428.2	376.8	330.9	258.5	202.4	146.2	122.6	88.9	74.7	55.8	42.9	36.6	32.3	24.5	20.2	10.6
1.67V/cell	440.8	388.7	340.6	265.5	205.3	148.4	124.4	90.2	75.8	56.3	43.6	37.4	32.4	24.8	20.5	10.7
1.60V/cell	454.4	402.0	351.1	272.4	208.3	150.5	126.2	91.5	76.9	56.8	44.1	37.9	32.7	25.2	20.7	10.9

Constant Power Discharge (Watts/cell) at 25°C (77°F)																
F.V/Time	5min	10min	15min	20min	30min	45min	1h	1.5h	2h	3h	4h	5h	6h	8h	10h	20h
1.85V/cell	721.2	529.0	480.9	379.9	341.2	251.1	213.9	155.5	131.1	96.6	76.1	66.3	58.6	45.3	37.6	20.0
1.80V/cell	806.9	591.8	537.9	424.9	368.6	264.3	220.4	160.0	134.7	104.4	80.9	69.4	62.7	47.5	39.3	20.7
1.75V/cell	861.1	631.6	574.1	453.5	373.2	272.2	230.2	167.4	141.3	106.1	82.2	70.4	63.0	47.6	39.7	20.8
1.70V/cell	905.3	664.0	603.5	476.8	377.5	275.7	233.6	170.0	143.5	107.8	83.3	71.4	63.3	48.3	40.0	21.0
1.67V/cell	920.0	674.8	613.3	484.5	380.2	278.2	235.7	171.6	145.0	108.3	84.3	72.6	63.4	48.9	40.5	21.3
1.60V/cell	932.9	684.2	621.9	491.3	381.8	279.6	237.5	173.0	146.2	108.8	84.9	73.3	63.6	49.4	40.9	21.5

Note: The above characteristics data can be obtained within three charge/discharge cycles.

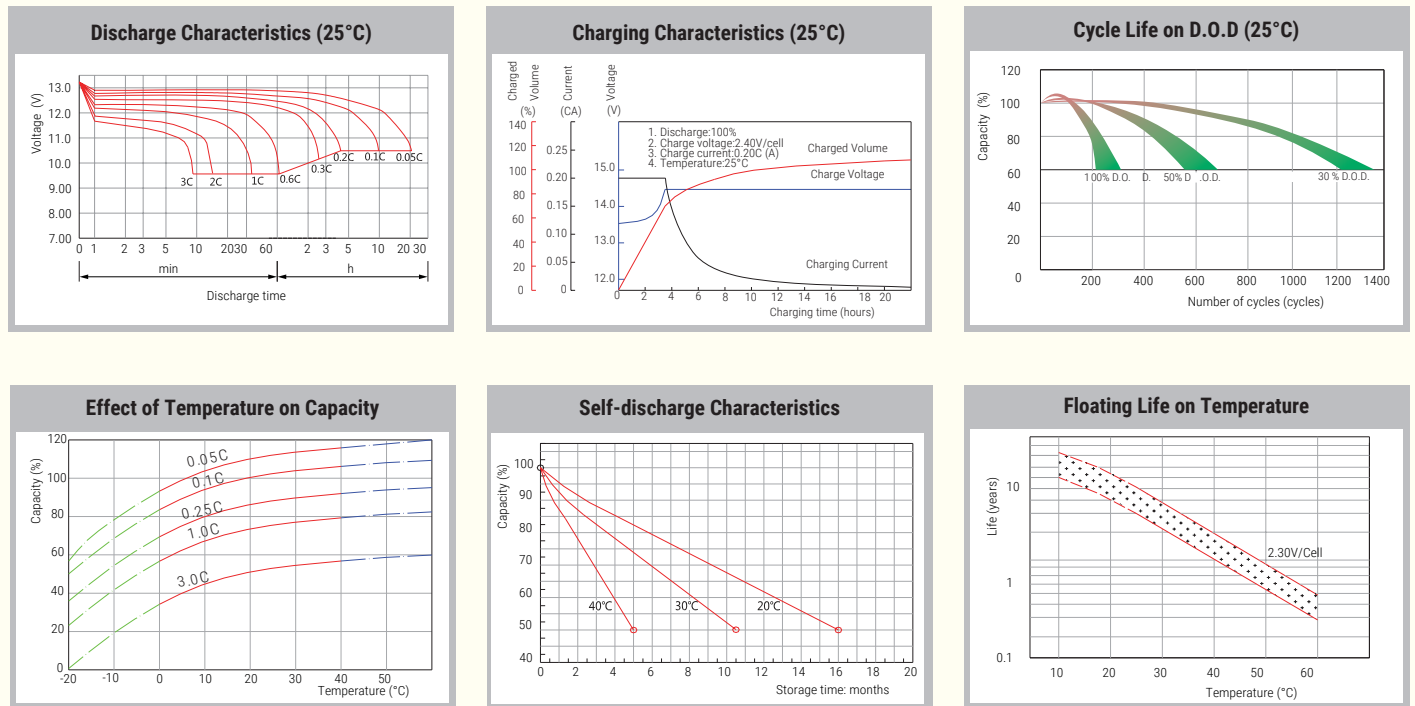

This specification provided by Lab report might differ from the practically tests.

